

CIP+Plus™

CLEANING IN PLACE (CIP) SYSTEM

The Heavy Duty General Purpose Sanitary Total Recovery Cleaning In Place System for all sectors

Overview

These skid mounted systems provide a robust and repeatable method of cleaning process equipment with water and added chemicals, such as detergents and sanitisers.

Skids comprise all the necessary heaters, pumps, valves, pipework, water and/or chemical storage tanks and related components and instrumentation to deliver the required CIP cycle. Type, quantity and physical sizes of components are determined during the design phase of each project to suit the required application.

System construction and components are suitable for sanitary use in food, beverage and other hygienic applications.

Systems include a user-configurable recipe based control system to suit a wide range of applications and are pre-assembled and fully tested with operating utility supplies in our works to minimise risk and optimise installation and commissioning time on-site.



Applications

- ✓ Cleaning of Tanks
- ✓ Vessels
- ✓ Road Tankers
- ✓ Intermediate Bulk Containers (IBCs)
- ✓ Vats, Fermenters
- ✓ Mixers Processors
- ✓ Pipework Flexibles
- ✓ Transfer Line Valves
- ✓ Fluid Bed Dryers Mills
- ✓ Coaters Filters
- ✓ Pumps
- ✓ Dryers Tumblers
- ✓ Fillers
- ✓ and many more.

Sanitary Construction

- ✓ Sanitary components with no threads and triclamp connections
- ✓ 316 Stainless Steel Sanitary Pipework, no dead legs, fully drainable, certificate of conformity.
- ✓ 304 Stainless steel framework
- ✓ Control and instrumentation to industry best practice
- ✓ Repeatable, reliable client configurable sequences

Welcome

Since our foundation in 1961, Suncombe has pioneered the development of innovative solutions for cleaning in place, GMP Washers, skids, tanks and vessels and bio-waste decontamination. The business continues to be privately owned and managed day to day by Dave Adams and Steve Overton.

Supporting Dave and Steve is a close-knit, dedicated, highly motivated and long-standing team encompassing a wealth of technical experience and knowledge in all relevant disciplines, including design, manufacture, testing, installation, validation, documentation and after-sales support. All of our work is carried out across our own facilities north of London near Stansted Airport.

The team employ the very latest techniques, standards and best in class solutions. Having such a strong team allows us to offer the ability to carry out all of our work in-house, under our direct control

and quality management system. It also ensures that we own and preserve all the knowledge and experience gained with every project and allows us to offer continued support for all our installed systems throughout their lifetime.

Our Clientele



Our Equipment

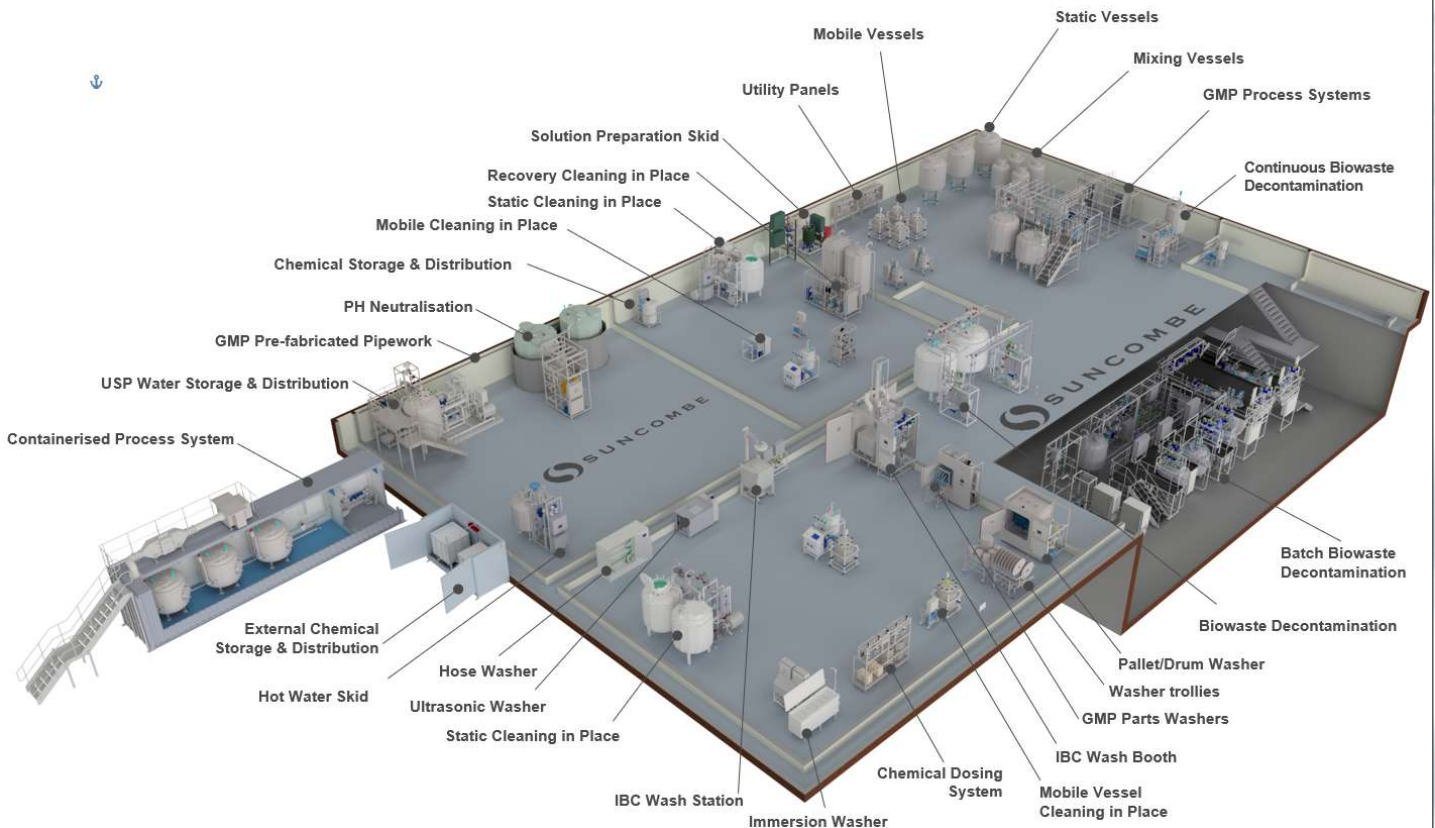

Suncombe Ltd

Suncombe House, Unit B Woodside Industrial Estate, Dunmow Road, Bishop's Stortford, CM23 5RG, United Kingdom
 T +44(0)20-8443-3454 F +44(0)20-8443-3969
 E info@suncombe.com W www.suncombe.com

CIP+Plus™ DATASHEET

VERSION 4.0

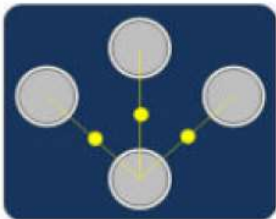

Key Features	Benefits
Sanitary 316L stainless steel construction and components	CIP fluids are maintained at a sanitary standards with butterfly valves and 2.2 material certification.
Variable Duty Delivery Pump	316L Stainless Steel Heavy Duty Sanitary Delivery Pump with Variable Speed Drive to allow speed control to vary the delivery flowrate and pressure from the recipe, complete with PID loop
Vessel Mixing Pumps	316L Stainless Steel Heavy Duty Sanitary Mixing Pumps to prepare heated chemical batches in the tanks prior to delivery
Siemens PLC and 6"/12" colour HMI with options for additional HMIs	Control hardware is industry standard and supported worldwide by Siemens. Ethernet interface included for transfer of critical operating variables to other systems. Designed to enable integration to third party equipment or higher level control system. Versions also available with remote I/O for control by clients control system.
Suncombe SmartCIP™ software	Control software specification has been developed and proven over many years for CIP applications and includes a wide range of user or administrator configurable parameters to enable customised cleaning recipes, including water flow, pressure, time, temperature, chemical concentration and many more. Electronic CIP batch reports for local or network storage are possible. User interface screens and process visualisation is simple, intuitive, clear and comprehensive. Remote access options are possible if required.
CIP Tanks	316L Stainless Steel Atmospheric tank, sanitary construction with riboflavin tests. Water storage or chemical make-up vessels.
Total or Partial recovery options	Options available for Partial Recovery (only CIP chemical solutions are re-used) or Total recovery (the CIP chemical solutions and the final rinse are re-used), to reduce overall water, chemical and energy consumption.
Continuous Cycles	Facilities included to heat and chemically dose chemical tanks during later rinses to ensure system is immediately available for next cycle with no waiting time.
Low Thermal Utility Usage	Facilities included to pre-heat tanks before the cycle starts, to minimise immediate high loading on your thermal utility.
Steam, hot water/oil/gas heating options	Heating energy may be derived from most convenient and cost-effective source available.
Continuous monitoring of key parameters	CIP process is highly robust and repeatable.
Chemical Solution Tanks	1, 2, 3 or 4 chemical tanks can be used to generate the chemical solutions
In-line chemical dosing	Delivery of 1, 2, 3 or 4 chemicals in-line (often used for sanitiser solutions)
Scavenge/Return	Skid prepared to accept return of fluids from optional scavenge pump/s, gravity drains or other site method of equipment liquid return
Plug 'n' Play	Comprehensive in-house testing to ensure fast start up on site
CIP Distribution	A single CIP outlet is included. Options available for up to 10 separate CIP outlets for feeding to different items to be CIP'ed. Each outlet can be a single or double valve for CIP isolation. Distribution can also be via flowplate/splitter panel.
	
	Typical flowplate/splitter panel
Simultaneous Cycles	Available with single CIP feed and return (1 channel) with multiple channels also available (up to 6 channels) which can be running simultaneously
Instruments	Sanitary instruments of Endress and Hauser/Mettler Toledo or equivalent with full material and calibration certification.

CIP+Plus™ DATASHEET

VERSION 4.0

Diagram

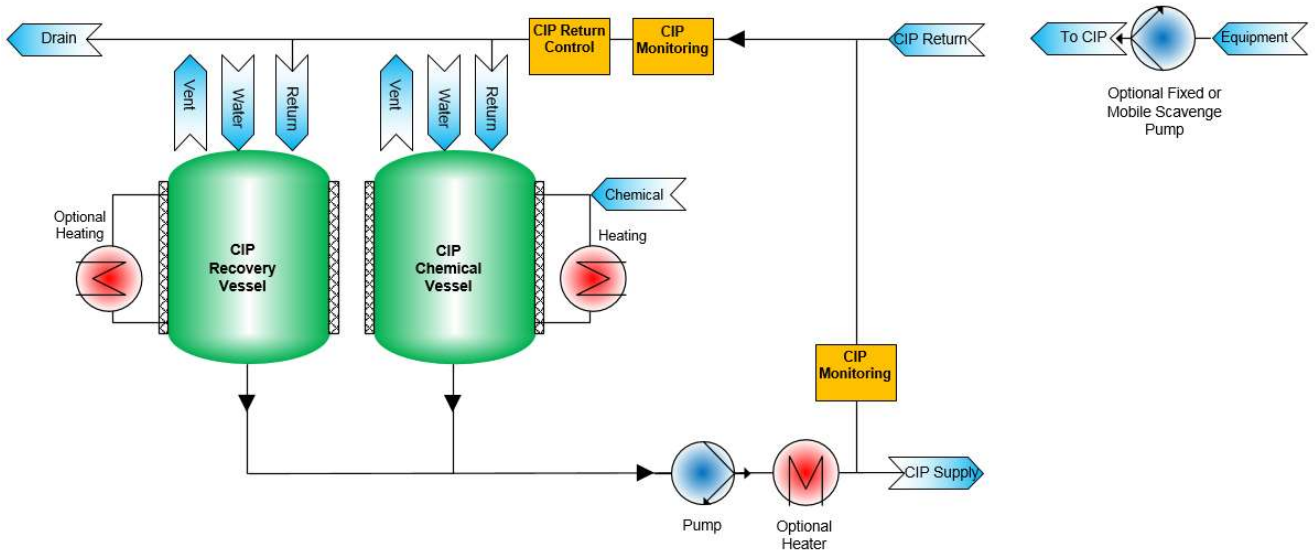

Layout Drawing

This is typical for 2 tank version

Dimensions

These are typical only and should be confirmed.

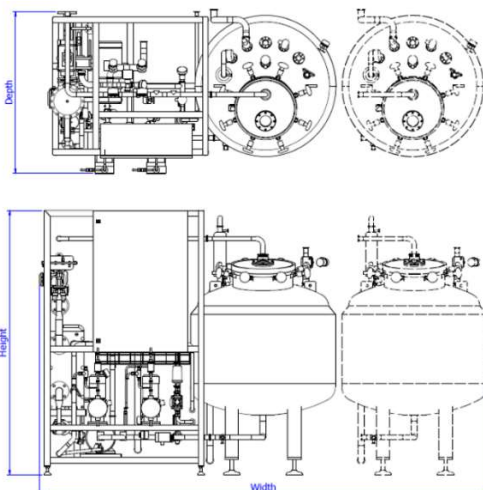

Part #	Vessel Capacity Litres	Flowrate Litres per minute	Length mm	Width mm	Height mm
CIP+ Plus™ 600	600	0-100	3,200	1,000	1,800
CIP+ Plus™ 1000	1,000	0-250	4,000	1,000	1,800
CIP+ Plus™ 2000	2,000	0-500	4,500	1,250	2,100
CIP+ Plus™ 3000	3,000	0-1,000	5,000	1,500	2,350
CIP+ Plus™ 5000	5000	0-1,000	5,000	2,000	2,350
CIP+ Plus™ 10000	10000	0-1,250	6,000	2,000	3,000

Dimensions with 2 tanks, one chemical and one rinse.
 All Systems also available with 1, 3, 4 or more vessels.
 Dimensions with single CIP feed and return (1 channel), multiple channels also available (up to 6 channels)

CIP+Plus™ DATASHEET

VERSION 4.0



Typical CIP+ Plus™



Typical CIP+Plus™
Operator Interface HMI

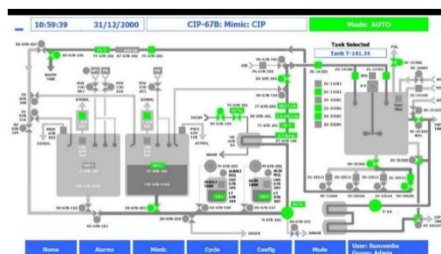

Typical CIP+Plus™ Operator Interface
HMI Recipe Configuration

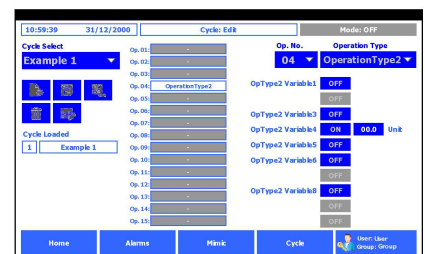

Utilities

Water (towns, soft, RO etc)	100 – 1,250 litres/min @ 1 bar (dependent on tank usage)
Compressed Air (internal regulator)	Minimal use @ 7bar
Electricity	>18 kW 400Vac 3ph+n 50hz. Other voltages available to order
Steam and Condense	To be confirmed dependant on system duty @ 3 bar
Drain	100 – 1,250 litres/min @ 1 bar (as per system flowrate)

CIP+Plus™ DATASHEET

VERSION 4.0



Diagram of Typical Two channel Configuration

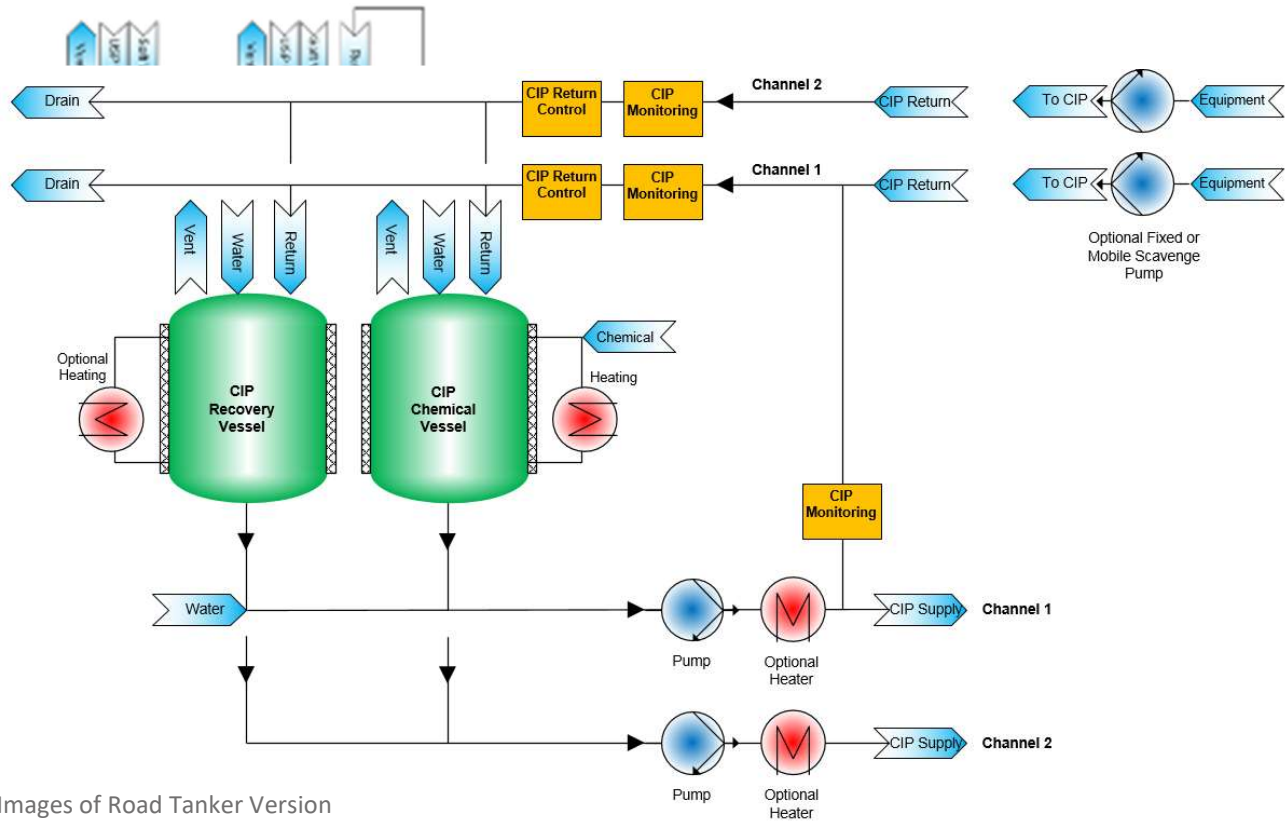

Images of Road Tanker Version



Images of Containerised Version



